

Fiero 2114

*Enthusiasts Guide to the
Pontiac Fiero a look into
the 1984 Fiero Highlights*



Fiero 2114

Exploring the 1984 Fiero

- The Fiero was the first mass-produced American mid-engine sports car
- There was only 41 pilot cars produced starting in January 1983
- The Fiero was only available in either red or white
- Once produced it became the top selling two-seat sports car in American automotive history by April 1984



Fiero 2114

The Pontiac Fiero was selected as the official pace car of the 68th running of the Indianapolis 500 on May 27th, 1984; was the first four-cylinder car to pace the race since 1912.



Fiero 2M4

1984 Pontiac Fiero by the numbers

- **Total number produced – 136,840**
- **% of total production of 370,168 – 36.97%**
- **MSRP range from the Coupe to the Indy Pace car - \$8,195-12,482**
- **The base 1984 Fiero model was equipped with a economy manual transmission which achieved a mileage rating of 50 miles per gallon**



Fiero 2114

The Pontiac Fiero was the first automobile to incorporate the use of a space-frame design. This means that the plastic body panels were simply bolted onto a high strength steel sub-frame.

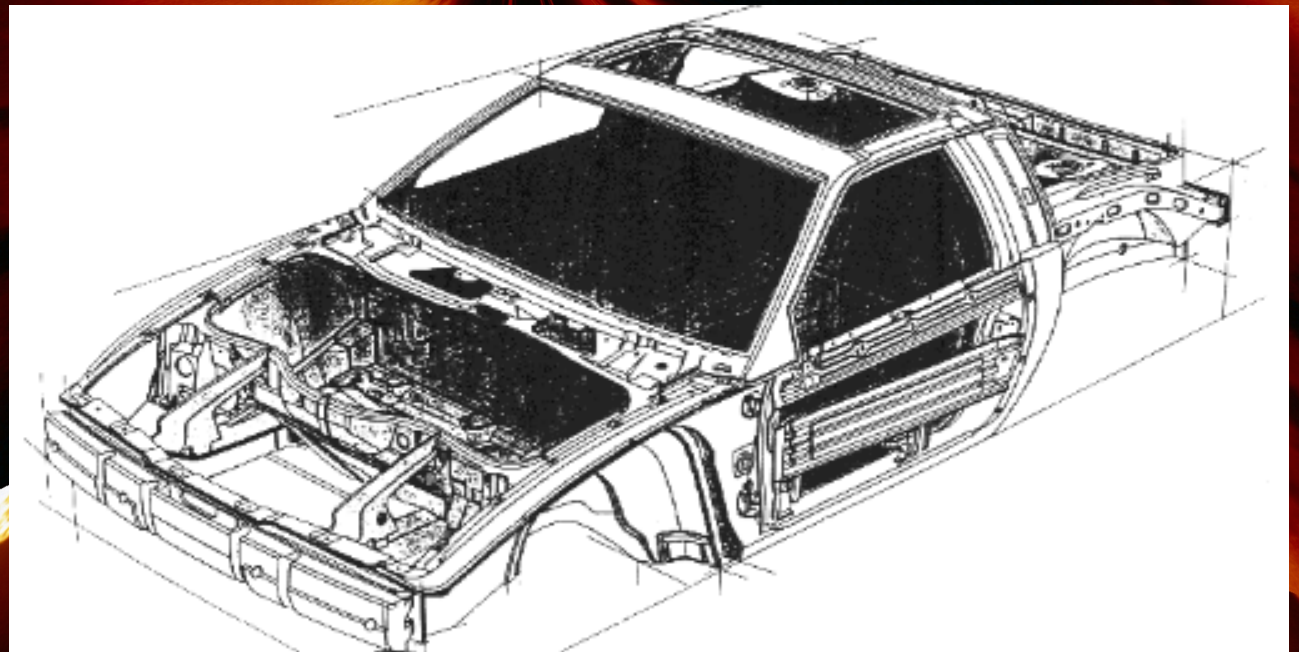

Fiero 2M4

If you would like more information on the 1984 Pontiac Fiero pick up your copy of the E.G. today! At the next Club meeting we will bring you the 1985 Pontiac Fiero highlights

